

f a m b u e n a

*News
spring
2008*



f a m b u e n a

Nos complace presentarle las novedades de fambuena para esta primavera 2008. Junto a nuestros diseñadores hemos creado dimensiones originales y colores más bellos a partir de las lámparas que ya han sido un éxito en la escena de la iluminación internacional. Asimismo llega un nuevo diseño a nuestro catalogo: Grace, que invitamos a conocer en estas próximas paginas

Wir freuen uns, Ihnen die neuen Ideen von Fambuena für das Frühjahr 2008 vorstellen zu können. Zusammen mit unseren Designern haben wir neue Dimensionen und neue wundervolle Farben für unsere Leuchten, entwickelt, die schon so erfolgreich in der internationalen Leuchtenlandschaft waren. Darüber hinaus haben wir eine neue Leuchte in unseren Katalog aufgenommen: GRACE, die wir Ihnen auf den folgenden Seiten vorstellen möchten.

We are pleased to introduce the new Fambuena ideas for Spring 2008. Along with our designers, we have created original dimensions and new beautiful colors based on the light fixtures that have already been successful in the international lighting landscape. In addition, a new design is brought to our catalog: Grace, the one that we invite you to meet in the following pages.

Nous avons le plaisir de vous présenter les nouveautés de Fambuena pour le printemps 2008. Avec nos designers nous avons créé des tailles beaucoup plus originales et des couleurs plus recherchées à partir des lampes qui ont déjà eu un réel succès sur la scène de l'éclairage contemporain international. De plus, un nouveau modèle s'ajoute à notre catalogue : Grace, que nous vous invitons à découvrir dans les prochaines pages.

Siamo veramente felici di proporvi le novità di Fambuena per la primavera 08. Con i nostri designer abbiamo creato originali dimensioni e colori sempre più ricercati per le lampade che sono già un successo sulla scena dell'illuminazione internazionale. Inoltre c'è un nuovo arrivo nel nostro catalogo: Grace, che vi invitiamo a scoprire nelle prossime pagine.

Contents



Grace

04

Dress

10

HangingHoop

18

SwingOne

24

Grace

antonio minervini 2008





Grace

7

Una nueva lampara en el universo Fambuena que con la frescura de su linea minimalista y elegante, aspira a convertirse en un nuevo "clasico" en la escena internacional.

A new light fixture in Fambuena's universe, that with the freshness of its minimalist design and elegance, aspires to become a new "classic" in the international landscape.

Una nuova lampada nel mondo Fambuena che con la freschezza del suo segno minimale ed elegante, aspira a diventare un nuovo "classico" nella scena internazionale.

Eine neue Leuchte im Fambuena Universum, die dank ihrer Frische und ihres minimalistischen Designs hoffen lässt, ein neuer „Klassiker“ in der internationalen Leuchtenwelt zu werden.

Une nouvelle lampe dans l'univers fambuena, qui avec la fraîcheur de ses lignes minimales et élégantes, aspire à devenir un nouveau "classique" dans la scène internationale.

Grace

antonio minervini 2008

Lampara de mesa en mármol pulverizado con una base giratoria en cromo negro. Grace se viste con un color monocromático blanco y en las variantes bicolor rojo rubí/blanco, crema/blanco y azul noche/blanco. Una luz cálida, sugestiva y direccionable que crea una forma ovalada de luz reflejada en el espacio.

Tischleuchte aus Marmorzement mit drehbarem, schwarz verchromtem Fuss. Grace wird entweder in weiss, dunkelblau/weiss, rot/weiss oder creme/weiss geliefert. Ein schmeichelndes suggestives und gerichtetes Licht, dass einen ovalen Lichtkegel in den Raum wirft.

Table lamp in crushed marble with a rotating base in black chrome. Grace is dressed with a monochromatic white color and also in variations of dual-color ruby red/white, Cream/white and dark blue/white. A cozy, suggestive and directional light that creates an oval-shaped light reflected in space.

Lampe de table en marbre pulvérisé avec une base rotative en noir chromé. Grace s'habille avec une couleur blanche monochromatique et avec des variantes bi-couleur rubis/blanc, crème/blanc et bleu nuit/blanc. Une lumière chaude, suggestive et orientable qui crée une forme ovale de lumière réfléchié dans l'espace.

Lampada da tavolo in marmo pulverizzato con base rotante in cromo nero. Grace si veste nei colori bianco monocromatico e nelle varianti bicromatiche rosso rubino/bianco, tortora/bianco e blu notte/bianco. Una luce calda, suggestiva e direzionabile che crea un ovale di luce riflessa nello spazio.



TABLE

Incandescent
Max 1x150w E27



Energy saving
Max 1x23w E27



IP20

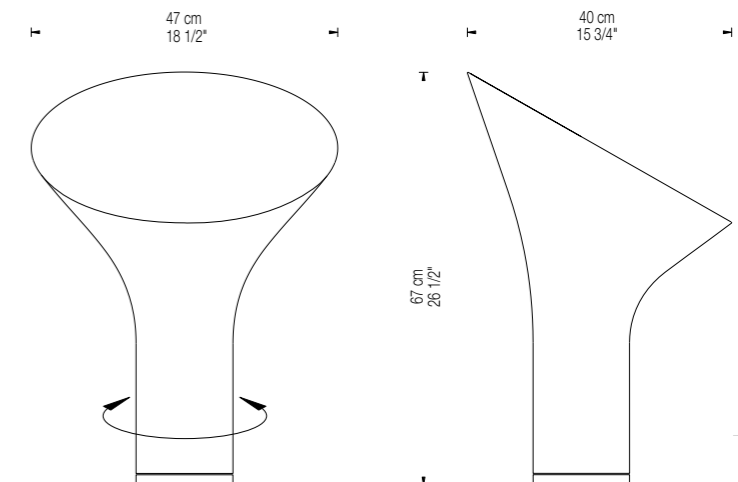

The new medium2 version of Dress

La medium2 es una medida que amplia la extensa gama de la versión colgante de la Dress.

The medium2 is a new size that adds to the already extensive range of the Dress pendant.

La medium2 è una dimensione che amplia la gamma già ricca di versioni a sospensione della Dress

Durch die Medium 2 wird die schon umfangreiche Produktpalette der Dress Familie sinnvoll ergänzt.

La medium2 est une mesure qui enrichie la large gamme du modèle de suspension Dress



The DressXL

la extensa colección de lámparas Dress se enriquece con una inesperada dimensión extra larga para su versión colgante.

Our Dress extended collection is enriched with an unexpected extra large version of its pendant model.

La ricca collezione delle lampade Dress si arricchisce di un'inaspettata versione extra large per la versione a sospensione.

Unsere Dress Kollektion wird durch eine unerwartet grosse Version der Pendelleuchte erweitert.

La large collection des lampes Dress, s'enrichit d'une version inattendue extralarge pour le modèle de suspension.





The Dress applique

No podía faltar en la colección Dress la versión de pared en dos medidas, aquí presentadas con una cinta de raso en un original color turquesa.

Non poteva mancare nella collezione Dress la versione a parete in due dimensioni diverse, qui presentate nello splendido raso turchese.

Elle ne pouvait pas manquer la collection Dress, la version murale avec deux modèles différents, vous est présentée ici avec un original ruban en satin turquoise.

Our Dress collection is completed by the new wall version in two sizes, presented this time with a satin ribbon in an original turquoise color.

Unsere Dress Kollektion wird durch eine Wandversion in 2 Größen erweitert, hier mit türkisfarbigen Satinbändern gezeigt

Lámpara de pie, mesa, colgante y applique de pared compuesta por una delicada estructura metálica envuelta en una cinta de raso. En colores blanco, rojo, turquesa, crema y negro.

Floor lamp, table lamp, pendant fixtures, and wall sconces are composed by a delicate metallic structure hand-wrapped with a satin ribbon. White, red, turquoise, ivory and black are the color options offered.

Lampada da terra, tavolo, sospensione e parete composta da un nastro in raso avvolto su un'esile struttura metallica nera. Nei colori bianco, rosso, turchese, avorio e nera. Dress è un vestito dinamico tra densità e trasparenza. La personalità elegante di un vestito di luce.

Pendel-, Tisch-, Steh- und Wandleuchten werden aus einer filigranen Metallstruktur mit von Hand gewickelten Baumwollsatinfäden gefertigt. Die angebotenen Farben sind: Weiss, Rot, Elfenbein und Schwarz.

Lampe sur pied, de table, de suspension ou murale composée d'une structure métallique noire très délicate, enroulée d'un ruban en satin noir. Dans les couleurs blanc, rouge, turquoise, ivoire et noir. Dress est un vêtement dynamique qui exprime densité et transparence. La personnalité élégante d'un voile de lumière.

WALL

Square
Incandescent
Max 1x100w E27



Energy saving
Max 1x23w E27







Rectangular
Incandescent
Max 2x60w E27

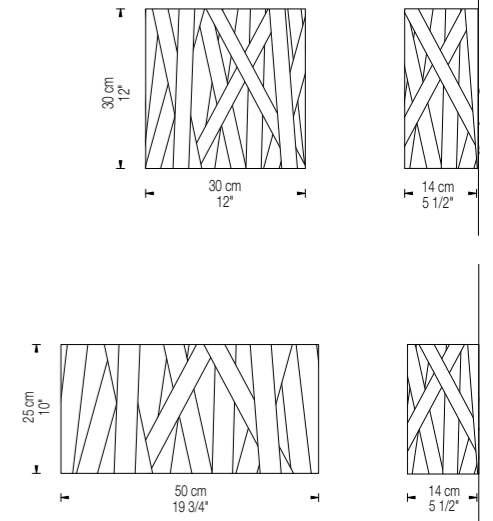

Energy saving
Max 1x23w E27



	medium2	XL	square applique	rectangular applique
	white cod.9022-01	cod.9023-01	cod.9024-01	cod.9025-01
	red cod.9022-02	cod.9023-02	cod.9024-02	cod.9025-02
	black cod.9022-03	cod.9023-03	cod.9024-03	cod.9025-03
	cream cod.9022-04	cod.9023-04	cod.9024-04	cod.9025-04
	turquoise cod.9022-05	cod.9023-05	cod.9024-05	cod.9025-05

PENDANT

XL
Incandescent
Max 3x150w E27



Energy saving
Max 3x23w E27



Medium 2
Incandescent
Max 1x150w E27



Energy saving
Max 1x23w E27

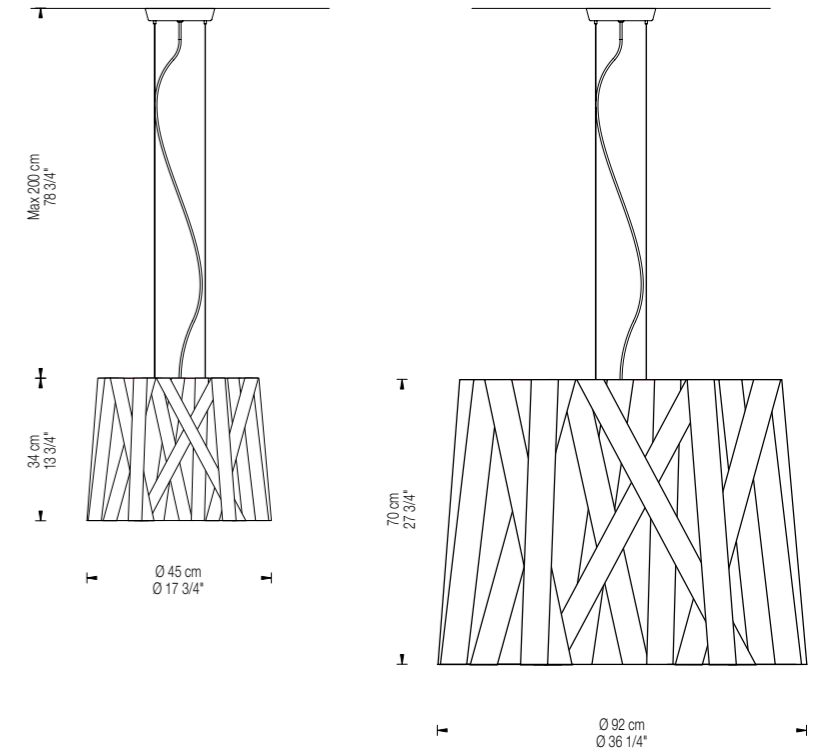

IP20



HangingHoop

nicola nerboni 2008

Un sorprendente desarrollo de la lámpara Hoop. En la nueva versión de suspensión un mecanismo permite el movimiento del disco variando la dirección de la luz y creando efectos escenográficos.

Un sorprendente sviluppo per la lampada Hoop. Nella nuova versione a sospensione un meccanismo permette il movimento del disco variando direzione della luce e creando scenografici effetti.

Une évolution surprenante de la lampe Hoop. Dans cette nouvelle version de lampe à suspension, un mécanisme permet le mouvement du disque en changeant la direction de la lumière et en créant des effets scénographiques.

A surprising evolution of our Hoop fixture. A special mechanism allows the disc to move, changing the direction of light and creating theatrical effects in this new version..

Eine überraschende Evolution unserer Hoop Leuchte. Ein spezieller Mechanismus erlaubt es, die Scheibe zu bewegen, die Lichtrichtung zu ändern, und so theatralische Effekte mit dieser neuen Version zu erzielen.



HangingHoop

nicola nerboni 2008

Plafón con disco difusor en metacrilato negro brillante. Gracias al mecanismo de rotación vertical y horizontal permite la creación de atractivos juegos gráficos a través de formas y luces difuminadas e indirectas. Con personalidad rigurosa y elegante en su esencia.

Pendant fixture that has a diffuser disc in glossy black acrylic. Its vertical and horizontal rotation mechanism allows the formation of attractive graffiti through indirect and blurred light shapes. This fixture has a rigorous personality and an elegant essence.

Lampada da soffitto con disco diffusore in metacrilato nero lucido. Grazie al meccanismo di rotazione verticale ed orizzontale permette la creazione di raffinati giochi grafici attraverso forma e luce riflessa ed indiretta. Rigorosa ed elegante nell'essere protagonista.

Pendelleuchte mit glänzend schwarzem Diffusor. Der vertikale und horizontale Rotationsmechanismus ermöglicht die Bildung attraktiver Graffiti durch indirekte und unscharfe Lichtkegel. Diese Leuchte überzeugt durch starke Persönlichkeit und elegante Substanz.

Un plafonnier avec un disque diffuseur en méthacrylate noir brillant. Le mécanisme de rotation verticale et horizontale permet de créer des jeux de lumières très raffinés à travers des formes et des lumières estompées et indirectes. Précise et élégante.

 black cod.9026-10 ø70 cm / 27 3/4"
black cod.9026-11 ø110 cm / 43 1/2"



HANGING

ø70
Fluorescent circular T5
Max 1x40w



ø110
Fluorescent circular T5
Max 1x40w

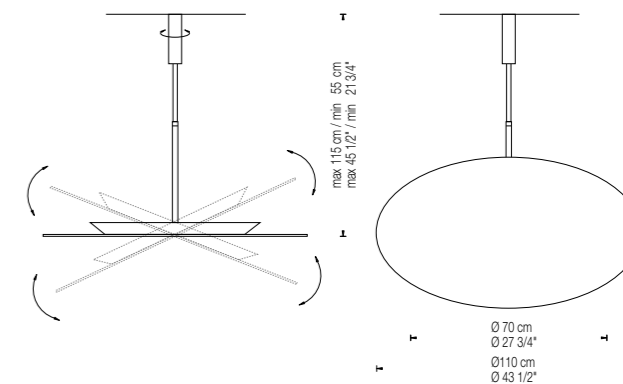

IP20



Swing One

nicola
nerboni
2008

En esta nueva versión la Swing y la Swing XL amplían sus posibilidades de uso con una sujeción fija al techo como alternativa a su ya conocida movilidad mediante un mecanismo tradicional.

The new Swing and Swing XL versions extend their useful possibilities with a hard-wired pendant fixture version that mounts directly to the ceiling, as an alternative to its already well-known pulley option.

In questa nuova versione la Swing e la SwingXL ampliano le proprie possibilità di uso con un attacco a soffitto fisso in alternativa a quello mobile.

In dieser neuen Ausführung erweitern Swing und Swing XL die Einsatzmöglichkeiten um eine feste Montage alternativ zur Höhenverstellbarkeit.

Dans cette nouvelle version la Swing et la Swing XL agrandissent ses propres possibilités d'usage avec une fixation au plafond comme alternative au mécanisme traditionnel mobile.



Lampara de suspension con sistema fijo de sujecion y con acabado en metalico cromo negro o pintado blanco brillante. Compuesta por hilos en tejido de algodón blanco, negro intenso y tambien en rojo carmin, verde salvia,gris claro,violeta,marron y blanco cuerda. Imprevisibles juegos de luces, Swing crea ambientes de glamour e intimidad. Existe ademas en la version tradicional regulable en altura a traves de un contrapeso.









Hard-wired pendant fixture with metal finish in Black Chrome or Glossy White. Composed of cotton strands in white, intense black, Carmine Red, green, gray, violet, brown, and flax. Unforeseen games of light, Swing creates environments of glamour and intimacy. Also available is the original, plug-in pulley version that allows you to change the shade height via a counterweight.

Lampada a sospensione con attacco fisso in metallo cromo nero o laccato bianco lucido. Composta da fili in tessuto in cotone bianco, nero intenso ma anche rosso carminio, verde salvia, grigio chiaro, viola, marrone e bianco corda. Imprevedibile nei giochi di luce Swing si caratterizza nel creare ambienti di grande glamour e intimità. Esiste anche nella versione tradizionale regolabile in altezza tramite un contrappeso.

Pendelleuchte mit starrer, schwarz verchromter oder glänzend weiss lackierter Befestigung. Baumwollfäden in den Farben weiss, tiefschwarz, karminrot, salbeigrün, hellgrau, violet, braun oder flachs. Unvorhersehbare Lichtspiele schaffen intime Ambiente mit grossem Glamour.

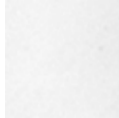
Lampe à suspension avec un système de fixation au plafond, finition métallique en noir chromé ou blanc brillant. Composée de fils en coton blanc, noir intense mais aussi rouge-carmin, vert-sauge, gris clair, violet, marron et écreu. En un jeu imprévisible de lumières et d'ombres, Swing crée le glamour dans une ambiance intime. Elle existe aussi dans la version traditionnelle avec une hauteur réglable grâce à un contrepois métallique.

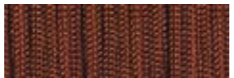
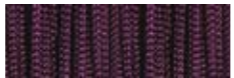

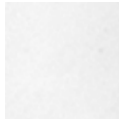
	med ø30	 white cod.9027-01	 black cod.9027-02	 red cod.9027-03	 green cod.9027-04
	XL ø50	white cod.9028-01	black cod.9028-02	red cod.9028-03	green cod.9028-04
	med ø30	white cod.9027-09	black cod.9027-10	red cod.9027-11	green cod.9027-12
	XL ø50	white cod.9028-09	black cod.9028-10	red cod.9028-11	green cod.9028-12
					
	med ø30	flax cod.9027-05	brown cod.9027-06	violet cod.9027-07	grey cod.9027-08
	XL ø50	flax cod.9028-05	brown cod.9028-06	violet cod.9028-07	grey cod.9028-08
	med ø30	flax cod.9027-13	brown cod.9027-14	violet cod.9027-15	grey cod.9027-16
	XL ø50	flax cod.9028-13	brown cod.9028-14	violet cod.9028-15	grey cod.9028-16

PENDANT
swingOne
cod.9027

Incandescent
Max 1x60w E27
N.America / Japan
Max 1x60w E26 120v



Energy saving
Max 1x20w E27



swingOne XL
cod.9028

Incandescent
Max 1x150w E27
N.America / Japan
Max 1x150w E26 120v



Energy saving
Max 1x23w E27



IP20

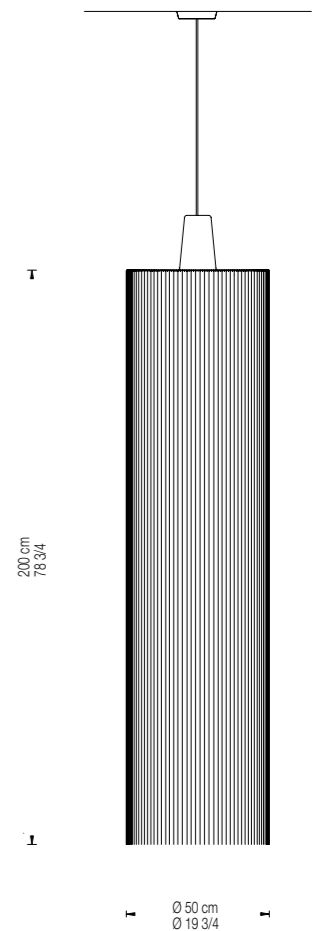
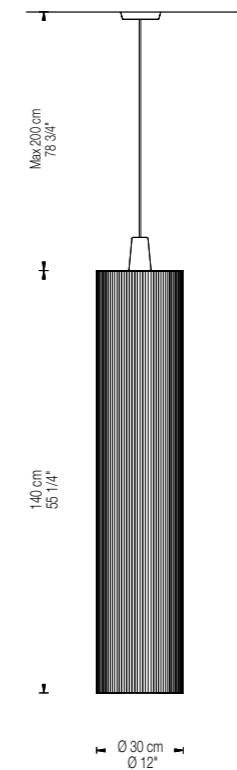



vicente garcía jiménez
spain



nicola nerboni
italy



cristian malisan
italy



sabine leuthold
switzerland



jéhs+laub
germany



antonio minervini
italy

Designers

making of



to be continued...

Credits

art direction : Vicente García Jiménez

graphic : Antonio Minervini / Poliedro

layout : Anna Pinatto / Poliedro

photography : Ana Yturralde

hair & make up artist : Josep Navarro

stylist : Javier Soria

model : Isabel Felú

photos pp. 3 & making of: studio VGJ

thank you very much :

Boutique Design Products, Inc.

Daniel P. Rosenbach

Daniele Zanchetta

Enrique Chust

Hans-Rüdiger Bruckmann

Reme Tortosa

Lourdes Lopez

Julie Bouteiller

Imprenta Vila

Fluxhouse

f a m b u e n a

Fambuena Luminotecnia S.L.

CI Fundación Marqués de Dos Aguas_12/14

Polígono Industrial de Massanassa

46470 Massanassa_Valencia_Spain

T +34 961 520 412 F +34 961 524 442

info@fambuena.com_www.fambuena.com

f a m b u e n a

Fambuena Luminotecnia S.L.
CI Fundación Marqués de Dos Aguas_12/14
Polígono Industrial de Massanassa
46470 Massanassa_Valencia_Spain
T +34 961 520 412 F +34 961 524 442
info@fambuena.com_www.fambuena.com